

# INSTALLATION INSTRUCTIONS

230 V, 50 Hz, 3.0 A SUITMATE® Unit

*If applicable, the following installation instructions can be followed for a 230 V, 60 Hz, 4.3 A SUITMATE® unit.*

The SUITMATE® Swimsuit Water Extractor has been designed and manufactured with safety as the primary consideration. Therefore, it is important that the unit be installed correctly. It is also important that the installation comply with all local building codes and regulations. Please consult your local licensed plumbing and electrical engineers or contractors about your installation. Read the entire INSTALLATION INSTRUCTIONS before beginning your installation. Remember: DO IT RIGHT and DO IT SAFE!

## PROPER LOCATION FOR THE SUITMATE® UNIT

Following is a list of factors to consider in determining a location for the SUITMATE® unit.

1. The unit should be located in an area that is near where people remove and rinse out their swimsuits.
2. The unit should NOT be located in a cluttered area or where it is exposed to direct shower water or water hose down.
3. The unit should be mounted on a wall structure that will support the unit's approximate 26 kg (58 lbs) hanging weight plus the added weight or pressure of people leaning on the unit. Consult the PROPER WALL MOUNTING section of these instructions to determine an appropriate location.
4. There should be a means to dispose of the wastewater from the unit. Consult the PROPER DRAINAGE section of these instructions (page 5) to determine an appropriate location.
5. The unit should be wired to a 230 V, 50 Hz, 13 A dedicated circuit. Consult the PROPER ELECTRICAL CONNECTIONS section of these instructions (page 5) to determine proper location.

## PROPER WALL MOUNTING OF THE SUITMATE® UNIT

The SUITMATE® unit should be mounted to the wall with the Wall Mount Bracket that is provided with the unit. The UTILITIES LOCATION DIAGRAM (page 9) shows the recommended location for the mounting holes, the electrical service, and the wastewater outlet (if utilized). The Wall Mount Bracket must be secured to a wall stud, or to concrete block or cinder block wall.

### **WARNING!**

***Anchors in drywall are not sufficient to mount the SUITMATE® unit.***

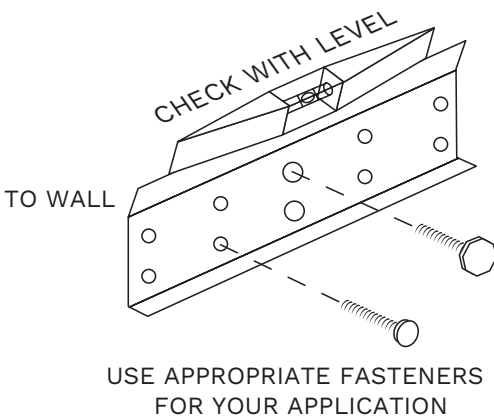

### **Locating and Securing the Wall Mount Bracket to the Wall**

The suggested height from the floor to the top of the SUITMATE® unit is 106.7 cm (42 in). At least an additional 25.4 cm (10 in) of clearance above the SUITMATE® unit is needed for the opening and closing of the lid. The upper center hole of the Wall Mount Bracket should be 96.5 cm +/- 1.6 mm (38 +/- 1/16 in) from the floor. The top of the Wall Sign should be 152.4 cm +/- 1.6 mm (60 +/- 1/16 in) above the floor and centered over the SUITMATE® unit. Determine a location on the wall that provides adequate clearance, a strong and secure place for the Wall Mount Bracket as well as easy access to electrical and drainage connections.

### **WARNING!**

***The Wall Mount Bracket must be level after it is secured to the wall.***

To secure the Wall Mount Bracket, center the bracket at the desired location and mark the locations of the two center holes. Secure the Wall Mount Bracket at the center holes using fasteners appropriate for your conditions. All fasteners must be capable of supporting 26 kg (58 lbs) in addition to the added weight or pressure of people leaning on the unit. Ensure the Wall Mount Bracket is level. Next secure the outer holes of the Wall Mount Bracket to the structure using fasteners appropriate to your conditions. After the bracket has been properly anchored to the wall and the electrical and drainage requirements have been allowed for, the SUITMATE® unit is ready to be mounted to the wall.

### **Mounting the SUITMATE® Unit to the Wall**

Remove the SUITMATE® unit from its shipping box. Remove and discard the packaging material that is protecting the SUITMATE® unit. **Remove the Bottom Plate that is attached with six screws.** Save the Bottom Plate, the six (AEC1147) mounting screws, and the six (AEC1704) lock washers, as they will be used to finish the installation of the SUITMATE® unit. The Bottom Plate will have two plugs inserted into it. Do not remove the plugs at this time. You will also find a packet containing two grommets. Save these grommets, as they may be required for final installation of the SUITMATE® unit. **Remove and discard the packaging material that is protecting the SUITMATE® motor.** The upper back lip of the SUITMATE® unit should be lowered down and centered on the Wall Mount Bracket. After the unit is centered, push down on the back of the unit to ensure that it is securely wedged onto the bracket and level. If it is not level, remove the unit, adjust the Wall Mount Bracket and re-hang the unit. A level installation is necessary to minimize vibration and ensure proper drainage of wastewater. Finish securing the unit to the wall using appropriate fasteners and anchors through the lower mounting channel at the bottom rear of the unit. This will prevent the unit from being lifted from the bracket or being moved.

**Note:** Several holes in the lower mounting bracket may be obstructed by the RCD Cover. Remove the RCD cover to provide access to these holes.

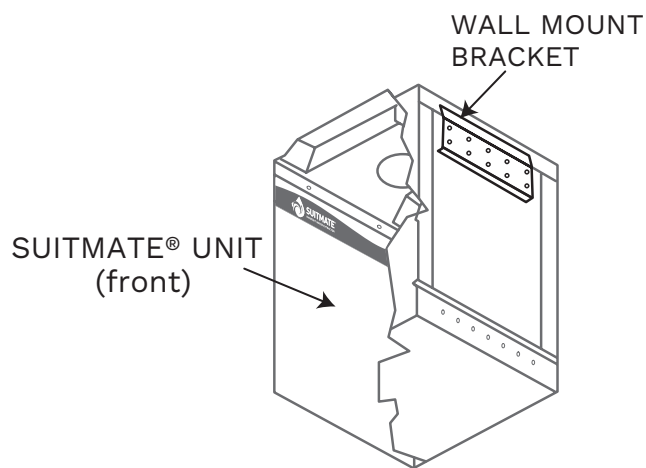
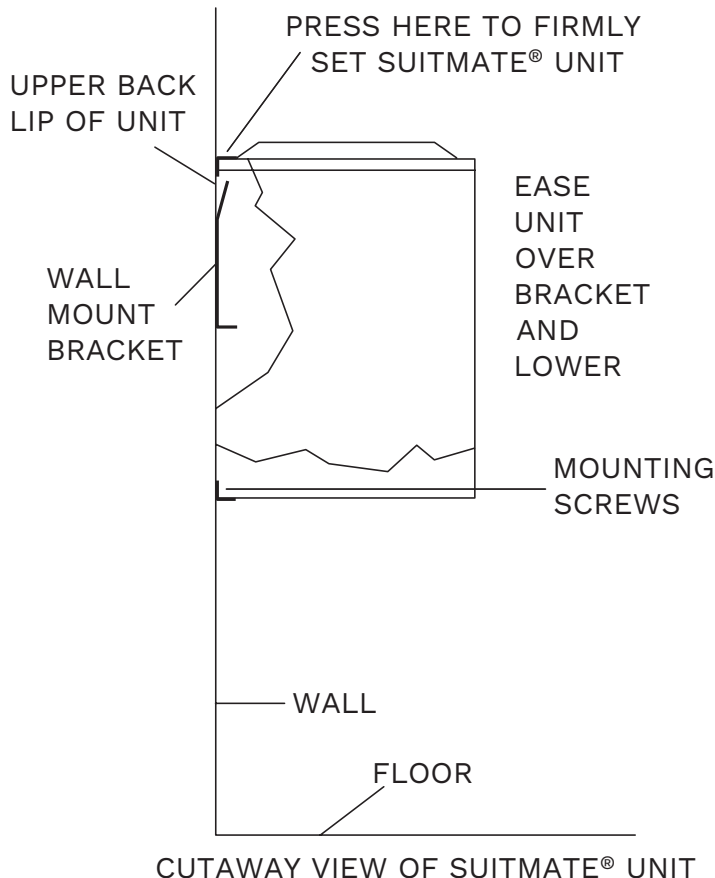

USE APPROPRIATE ANCHORS AND FASTENERS TO MOUNT THE UNIT FOR YOUR SPECIFIC INSTALLATION

## **PROPER DRAINAGE FOR THE SUITMATE® UNIT**

**Note:** *Strictly follow all applicable local plumbing codes and regulations.*

### **TO A FLOOR DRAIN**

Drainage of the wastewater to a floor drain should be done ONLY in an area where the floor is normally wet. DO NOT drain water across a floor where people do not expect to encounter a wet and slippery condition. The SUITMATE® unit comes with a short flexible drain hose and a stainless steel hose clamp that can be used to attach it to the unit's drain tailpiece. If using the provided drain tube, it must be routed through the 3.2 cm (1 1/4 in) I.D. Grommet in the Bottom Plate.

#### **WARNING!**

***The factory supplied drain hose or applicable equivalent MUST be installed on the unit unless the unit is connected to an approved wastewater outlet.***

### **Replacing the Factory Drain Hose with a Longer Drain Hose**

Use a 3.2 cm (1 1/4 in) I.D. drain hose with a smooth interior that will not crimp or collapse. Use the stainless steel hose clamp that is provided with the factory flexible floor drain extension tube to secure the replacement hose to the unit's drain tailpiece. Route the drain hose through the 5 cm (2 in) I.D. Grommet in the Bottom Plate so that it extends past the bottom of the SUITMATE® unit and always slopes down. Secure the drain hose to the wall or floor with properly sized "U" clamps so it cannot be maneuvered to trap wastewater. Cut off the end of the drain hose on an angle to help prevent it from being blocked by the floor, wall, or some other object. Upon completion of the installation, check to make certain that there is a free flow of water from the drain hose.

### **TO AN APPROVED SANITARY WASTE LINE**

This installation should only be done in accordance with all applicable local plumbing codes and regulations. The unit's 3.2 cm (1 1/4 in) O.D. drain tailpiece is designed for connection with standard compression type plumbing fittings. There is room inside of the stainless steel housing for the use of a standard "P" type plumbing connection. The waste outlet should be located in the wall behind the unit. The UTILITIES LOCATION DIAGRAM (page 9) shows the appropriate location for the waste duct.

## **PROPER ELECTRICAL CONNECTIONS FOR THE SUITMATE® UNIT**

#### **CAUTION!**

***Means for all-pole disconnection shall be incorporated in the fixed supply wiring to the unit, in accordance with the wiring rules. Always disconnect and lock out power using the disconnect means before beginning work on the SUITMATE® unit.***

**Note:** *Strictly follow all applicable local electrical codes and regulations.*

The SUITMATE® unit is equipped with a residual circuit device (RCD), that is designed to be connected to a 230 V, 50 Hz, 13 A dedicated circuit that is protected by a fuse or circuit breaker of the correct (13 A Maximum) size. The utilized circuit must be run to the SUITMATE® unit's weatherproof RCD Junction Box that contains the RCD. A liquid tight raceway/flexible conduit should be used from the circuit connection to the RCD Junction Box. The UTILITIES LOCATION DIAGRAM (page 9) shows the location of the suggested area behind the unit for the entrance of the electrical raceway or cable that does not interfere with the drainage connection.

#### **WARNING!**

***Do not route the raceway/conduit where wastewater can flow or drip on it.***



Remove the cover of the weatherproof RCD Junction Box, which contains the RCD, and remove the RCD. The circuit ground conductor must be connected to the Green/Yellow Earth Terminal located on the steel mounting rail in the RCD Junction Box. If no ground is available on the circuit utilized, you must provide a proper ground for the SUITMATE® unit. The incoming wires from your electrical service should connect to the “LINE” side of the RCD. Connect the hot lead to the terminal labeled “L1” and the neutral lead to the terminal labeled “N.” After the correct electrical connections have been properly made, remount the RCD. Reinstall the weatherproof Junction Box cover (the hinge must be located next to side of the case) previously removed. This cover provides access to the RCD “TEST” button.

## **POSTING THE WALL SIGN**

Locate the top edge of the sign 152.4 cm +/- 1.6 mm (60+/- 1/16 in) above the floor centered over the SUITMATE® unit. At this height the sign will not be blocked when the lid is raised.

The sign has an adhesive foam backing. Be certain that the mounting surface for the wall sign is clean and dry. Without touching the sign to the wall, align the top of the sign 152.4 cm +/- 1.6 mm (60+/- 1/16 in) above the floor and at the center of the unit. Press the sign to the wall and rub firmly over the adhesive portion of the sign.

## **TESTING AND OPERATION**

After the mounting and all connections are complete, test the SUITMATE® unit as follows:

1. Ensure all packaging material is removed from the unit including material around the Motor.
2. Check to see that the Basket is empty and that the Lid moves freely.
3. Press down on the Lid. The unit will start and run for 8 seconds. While the unit is running it should run smoothly and there should be no excessive vibration or noise.
4. Releasing the lid prior to the completion of the 8 second cycle will cause the Basket to stop within one (1) second.
5. Test the SUITMATE® unit by putting a wet swimsuit in the unit according to the instructions on the underside of the Lid. If there is excessive vibration or noise it is usually caused by the improper loading of the swimsuit. Be certain that the swimsuit is pushed to the bottom of the Basket and that all material is at least 5 cm (2 in) below the top of the Basket.

## **INSTALLATION TROUBLESHOOTING**

If the SUITMATE® unit does not operate, check the following:

1. Check to see if there is power going to the unit. Check the circuit using an A.C. voltmeter set to the appropriate range; measure across the “L1” side of the RCD.
2. Make certain that the RCD switch is in the “ON” position.
3. Check to see if there is power from the unit. Check the unit using an A.C. voltmeter to measure across the “LOAD” side of the RCD.
4. Check the TROUBLESHOOTING GUIDE (page 16) in this manual for additional troubleshooting assistance.

## **FINISHING THE INSTALLATION**

After the SUITMATE® unit has been tested and found to be in proper working order. The final step in the installation process is to replace the Bottom Plate on the bottom of the unit.

The Bottom Plate is labeled “This Side Out” and “This Side In.” It is important that the Bottom Plate be reinstalled in accordance with these labels. Be certain that the large rectangular opening in the Bottom Plate leaves access to the RCD cover. If the unit was electrically wired and plumbed from within the case, simply replace the Bottom Plate and fasten it with the six (AEC1147) screws and six (AEC1704) lock washers that were saved from the start of the installation process and retest the unit.

**CAUTION!**

***If the electrical wiring and/or plumbing connections are made from the outside of the unit, follow the instructions below to install the Bottom Plate.***

## **EXTERNAL ELECTRICAL SERVICE**

If the unit's electrical service is coming into the unit from the outside of the unit, it will be necessary to disconnect the incoming electrical service from the power source. Prior to disconnecting the electrical service make certain that the power source is turned off and locked out!

Remove and discard the small plug from the Bottom Plate, and replace it with the small rubber grommet that was saved from the start of the installation process.

The Bottom Plate is labeled "This Side Out" and "This Side In." It is important that the Bottom Plate be reinstalled in accordance with these labels. Be certain that the large rectangular opening in the Bottom Plate leaves access to the RCD cover.

Route the liquid tight raceway/flexible conduit through the grommet. If the unit has an internal plumbing hookup, work the Bottom Plate up to the bottom of the unit making certain that there are no kinks in the liquid tight raceway/flexible conduit, and that the grommet is secure in the Bottom Plate. If the unit uses an external plumbing hookup, proceed to the following instructions prior to fastening the Bottom Plate to the unit.

Otherwise fasten the Bottom Plate to the unit with the six (AEC1147) screws and the six (AEC1704) lock washers removed and retained from the beginning of the installation.

Properly reconnect the incoming power at its source to the RCD, remove the "Locked Out" warning from the power source and turn the power on. Retest the unit for proper operation.

## **EXTERNAL PLUMBING SERVICE**

If the unit's plumbing service uses the factory supplied Drain Hose or is connected from outside the unit, it will be necessary to disconnect the Drain Hose or piping from its external hookup. It will be necessary to route the factory supplied Drain Hose or piping through the Bottom Plate.

Remove and discard the large plug from the Bottom Plate and replace it with the large rubber grommet that was saved from the start of the installation. Run the Drain Hose or piping through the grommet. If the unit has internal electrical service, work the Bottom Plate up to the bottom of the unit making certain that there are no kinks in the Drain Hose, or piping, and fasten the Bottom Plate with the six (AEC1147) screws and six (AEC1704) lock washers removed and retained from the beginning of the installation.

If the unit has external electrical service, work the Bottom Plate up to the bottom of the unit making certain that neither the Drain Hose, or piping, nor the liquid tight raceway/flexible conduit, have any kinks in them. Fasten the Bottom Plate to the unit using the six (AEC1147) screws and six (AEC1704) lock washers removed and retained from the beginning of the installation. Reconnect the Drain Hose or piping to its external hookup. Also, if necessary reconnect the electrical service at its source making certain that the power source is turned off and locked out prior to reconnecting any wires to the unit. Retest the unit.

Be certain to save these instructions for future reference. If you require additional information, contact Extractor Corporation (Telephone) 1-847-742-3532 or (Email) [info@suitmate.com](mailto:info@suitmate.com).

With proper installation, use, and maintenance your SUITMATE® Swimsuit Water Extractor will provide you with years of trouble-free service.

# UTILITIES LOCATION DIAGRAM

230 V, 50 Hz, 3.0 A SUITMATE® Unit

If applicable, the following instructions can be followed for a 230 V, 60 Hz, 4.3 A SUITMATE® unit.

## WARNING!

**This diagram is for reference only! It is not to be used as the sole reference for installation of the SUITMATE® unit. The installation instructions must be followed explicitly!**

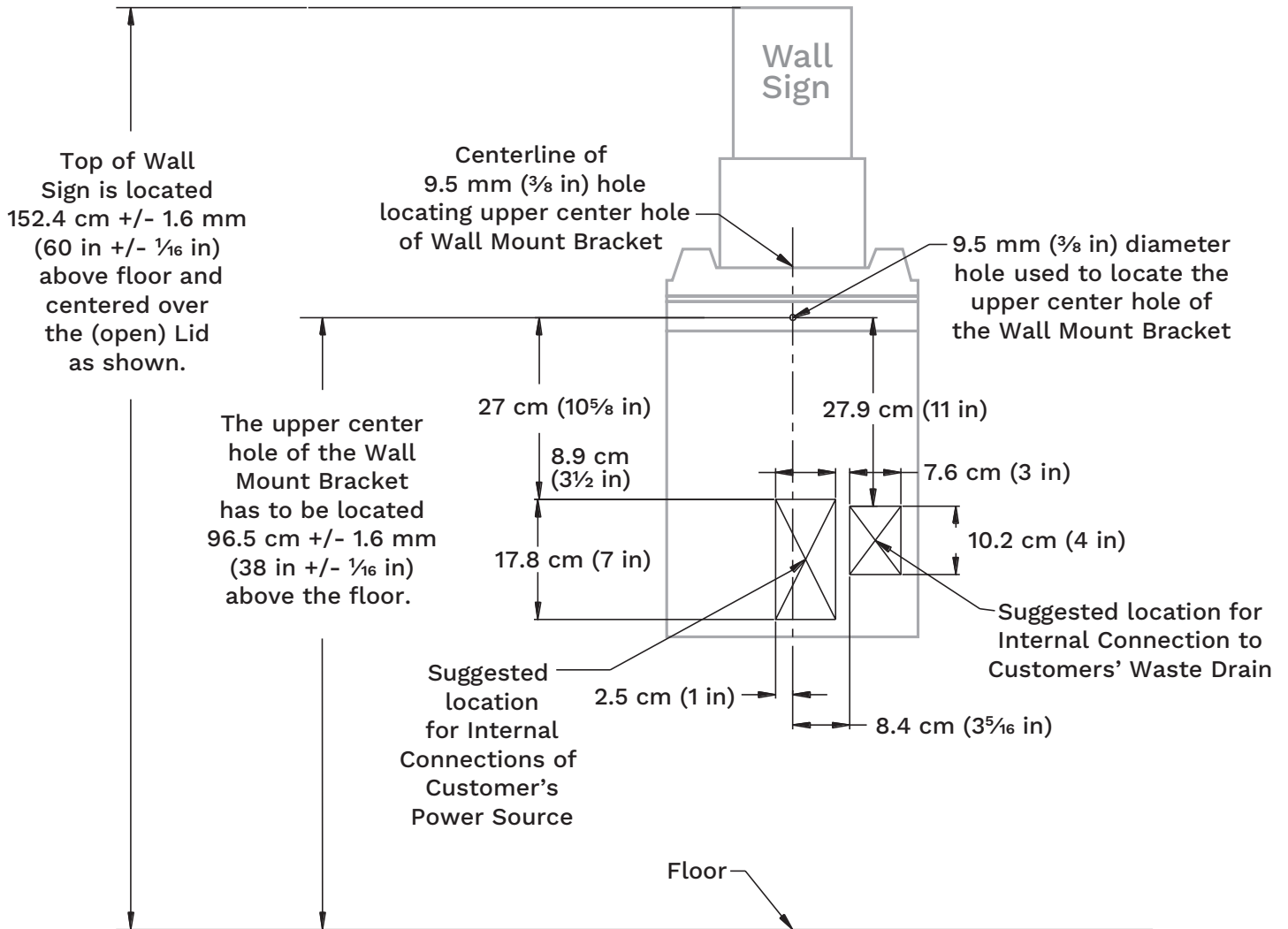

1. On wall locate center of 9.5 mm (3/8 in) hole for the upper center hole of the Wall Mount Bracket.
2. Draw a vertical line (down) from this mark to indicate the center of the lower mounting channel of the SUITMATE® unit.
3. Use given measurements to locate either or both locations for placement of internal utilities.
4. After the SUITMATE® unit is hooked over the upper bracket, move it side to side so the center hole in the bottom channel is over the vertical line drawn in Step 2.

## EXAMPLES OF INSTALLED SUITMATE®

**View showing Bottom Plate installed with internal plumbing and electrical connections.**

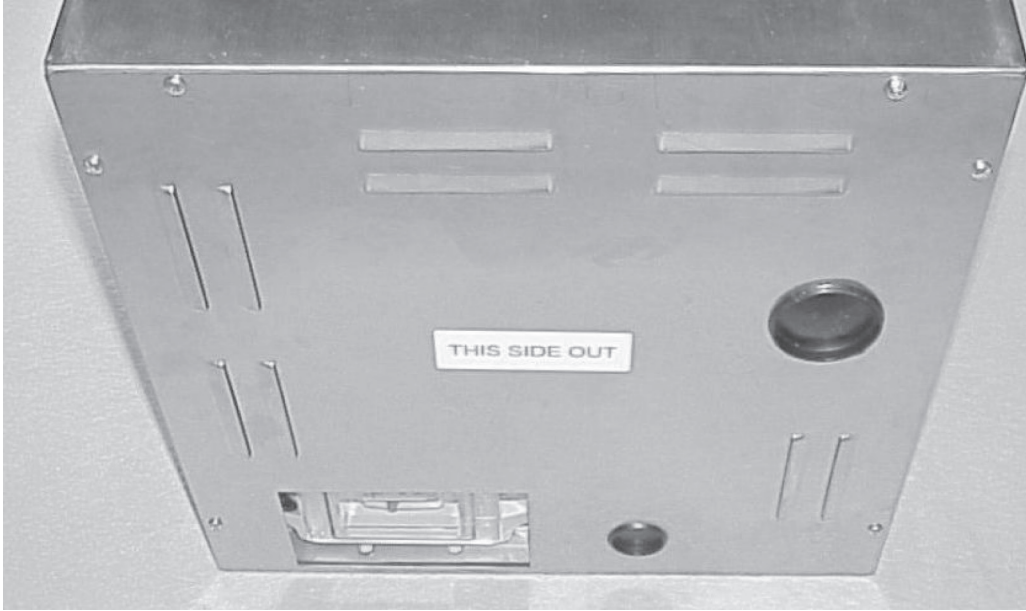

*The louvers are facing down, the Label reads "This Side Out", and the two Plugs are installed.*

**View showing Bottom Plate installed with internal plumbing and electrical connections.**

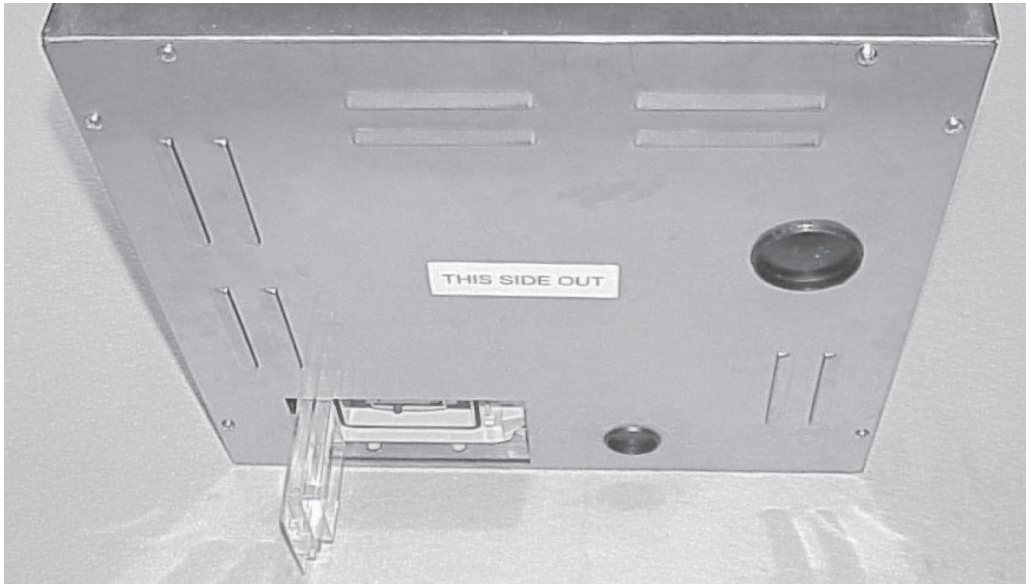

*Note position of RCD Box opening and the RCD box cover is open allowing access to the test button and reset switch.*



**View showing Bottom Plate installed with external plumbing and internal electrical connections.**

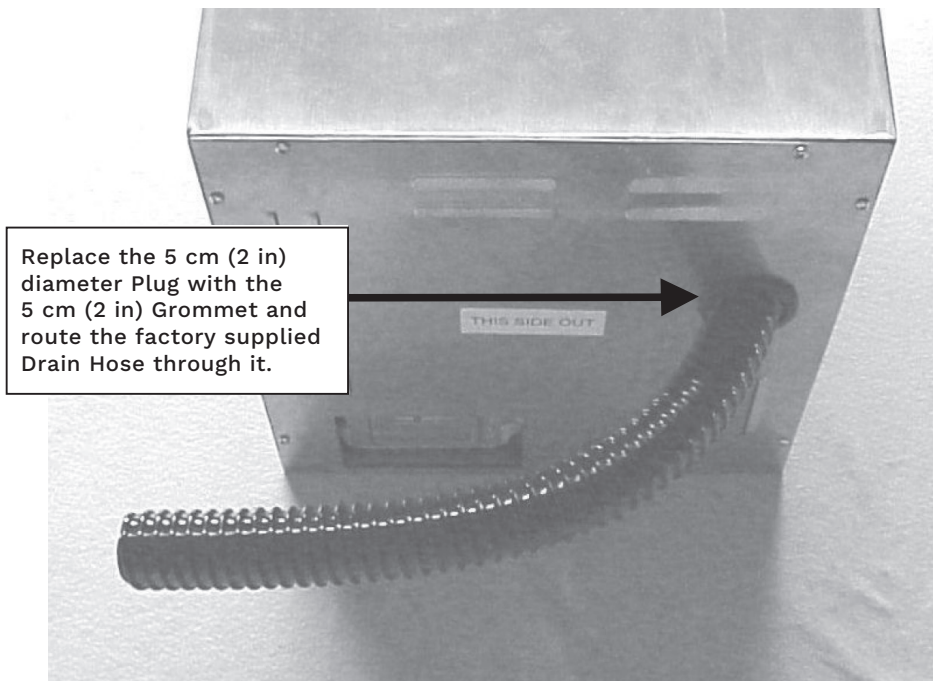

*The louvers are facing down, the label reads "This Side Out", and the 3.2 cm (1 1/4 in) diameter Plug is installed.*

**View showing Bottom Plate installed with external electrical and internal plumbing connections.**

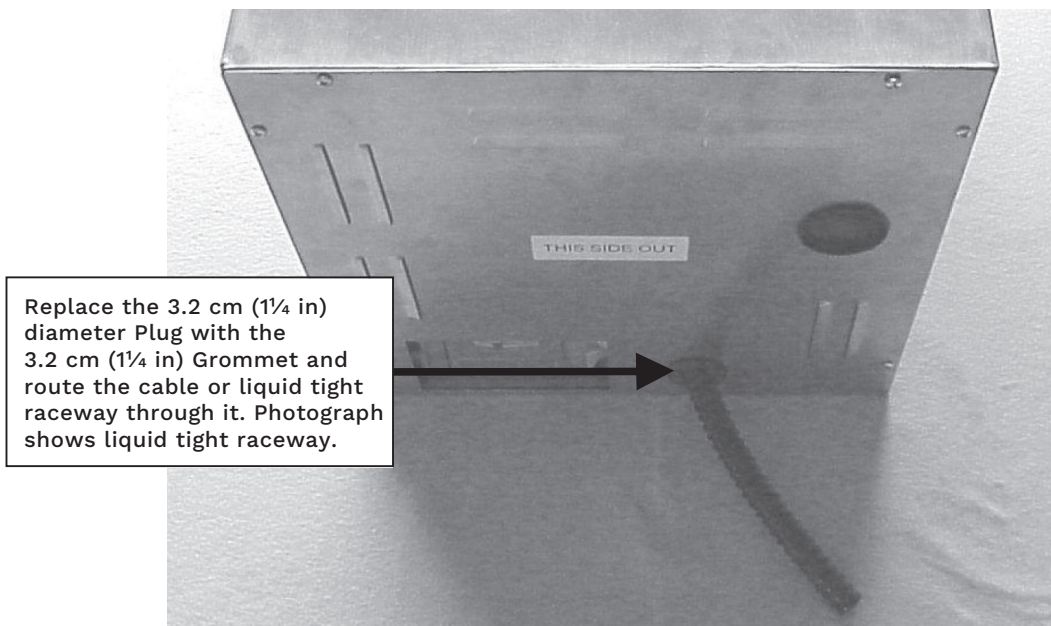

*The louvers are facing down, the label reads "This Side Out", and the 5 cm (2 in) diameter Plug is installed.*

**View showing Bottom Plate installed with external electric and external plumbing connections.**

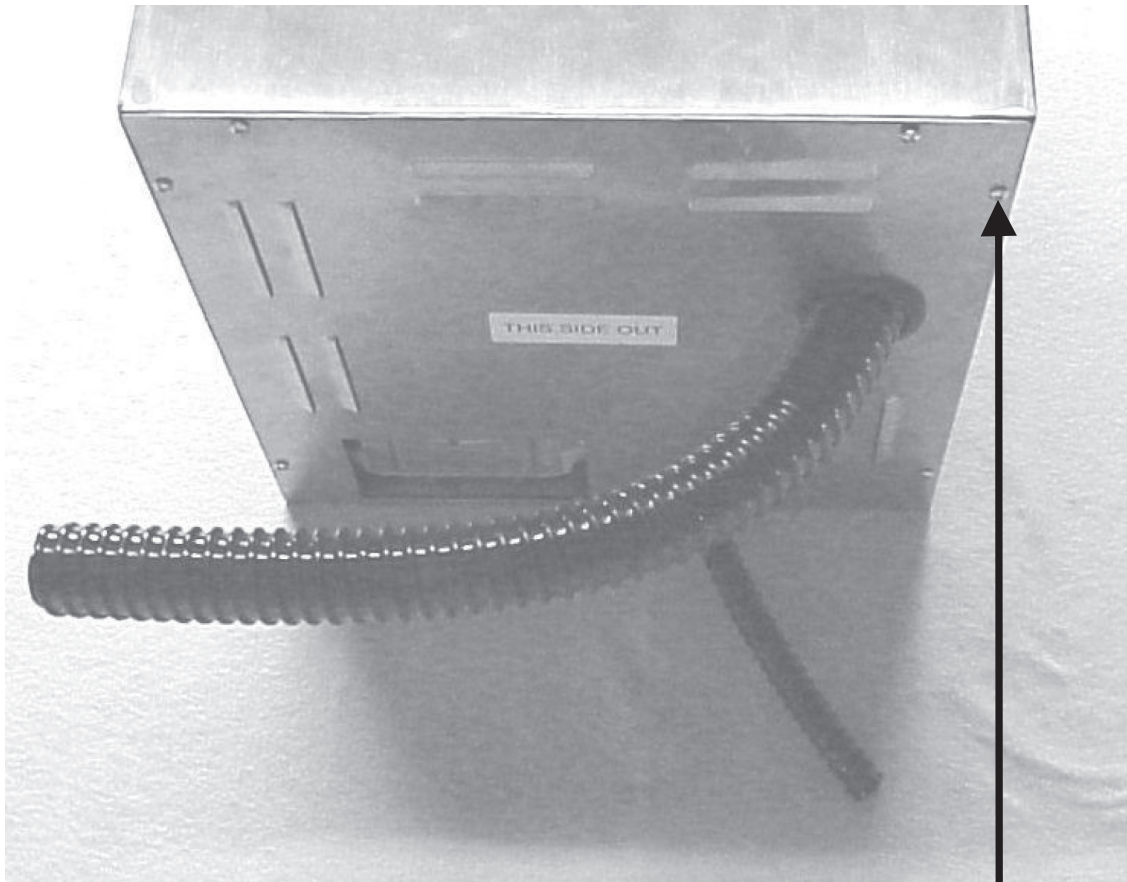

Remove and replace the (2) Plugs with the appropriate Grommets and route the cable or electrical conduit and the factory supplied Drain Hose through their appropriate Grommets prior to fastening the Bottom Plate.

Bottom Plate is fastened using (6) AEC1147 screws and (6) AEC1704 lock washers removed at start of installation.

*The louvers are facing down, the label reads “This Side Out”, and the RCD box cover is able to be opened for access to the RCD test button and reset switch.*