

INSTALLATION INSTRUCTIONS

115 V, 60 Hz, 8.6 A SUITMATE® Unit

The SUITMATE® Swimsuit Water Extractor has been designed and manufactured with safety as the primary consideration. Therefore, it is important that the unit be installed and maintained correctly. It is also important that the installation comply with all local building codes and regulations. Please consult your local licensed plumbing and electrical engineers or contractors about your installation. Read the entire INSTALLATION INSTRUCTIONS before beginning your installation. Remember: DO IT RIGHT and DO IT SAFE!

WHERE SHOULD THE SUITMATE® UNIT BE LOCATED?

Determine a location on the wall that provides adequate clearance, easy access to electrical and drainage connections, and a strong and secure place for attaching the Wall Mount Bracket, such as a wall stud, concrete or cinder block wall.

Following is a list of factors to consider in determining a location for the SUITMATE® unit.

1. Near where people remove and rinse out their swimsuits.
2. NOT exposed to direct shower water or splash-up from a water hose, sprayer or power washer.
3. Mounted on a wall structure that will support the weight of the unit and the pressure of a user depressing the lid; approximately 39 kg (85 lbs).
4. Near a floor drain if not being hard plumbed.
5. Wired to a 115 V, 60 Hz, 20 A, dedicated circuit, near an electrical connection point.

PROPER WALL MOUNTING OF THE SUITMATE® UNIT

The SUITMATE® unit should be mounted to the wall with the Wall Mount Bracket that is provided with the unit. The UTILITIES LOCATION DIAGRAM (available at www.suitmate.com under RESOURCES) shows the recommended location for the mounting holes, the electrical service, and the wastewater outlet (if utilized).

WARNING!

Anchors in drywall are not sufficient to mount the SUITMATE® unit.

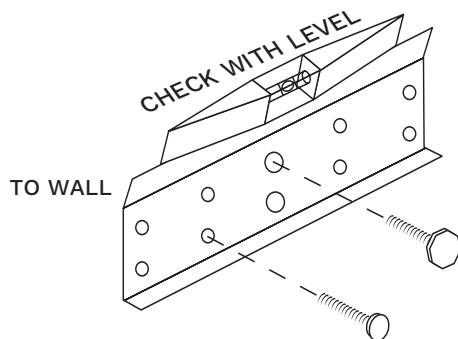

USE APPROPRIATE FASTENERS
FOR YOUR APPLICATION

Locating and Securing the Wall Mount Bracket to the Wall

The suggested height from the floor to the top of the SUITMATE® unit is 106.7 cm (42 in). At least an additional 25.4 cm (10 in) of clearance above the SUITMATE® unit is needed for the opening and closing of the lid. The upper center hole of the Wall Mount Bracket should be 96.5 cm +/- 1.6 mm (38 +/- 1/16 in) from the floor. The top of the Wall Sign should be 152.4 cm +/- 1.6 mm (60 +/- 1/16 in) above the floor and centered over the SUITMATE® unit.

WARNING!

The Wall Mount Bracket must be level after it is secured to the wall.

To secure the Wall Mount Bracket, center the bracket at the desired location and mark the locations of the two center holes. Secure the Wall Mount Bracket at the center holes using fasteners appropriate for your conditions (i.e. wall stud, concrete or cinder block). All fasteners must be capable of supporting the weight of the unit and the pressure of a user depressing the lid; approximately 39 kg (85 lbs). Ensure the Wall Mount Bracket is level. Next secure at least 4 of the outer holes of the Wall Mount Bracket. After the bracket has been properly anchored to the wall and the electrical and drainage requirements have been allowed for, the SUITMATE® unit is ready to be mounted to the wall.

Mounting the SUITMATE® Unit to the Wall

Remove the SUITMATE® unit from its shipping box. Remove and discard the packaging material that is protecting the SUITMATE® unit, including any material protecting the SUITMATE® motor. The upper back lip of the SUITMATE® unit should be lowered down and centered on the Wall Mount Bracket. After the unit is centered, push down on the back of the unit to ensure that it is securely wedged onto the bracket and level. If it is not level, remove the unit, adjust the Wall Mount Bracket and re-hang the unit. A level installation is necessary to minimize vibration and ensure proper drainage of wastewater. Finish securing the unit to the wall using appropriate fasteners and anchors through the lower mounting channel at the bottom rear of the unit. This will prevent the unit from being lifted from the bracket or being moved.

Note: Several holes in the lower mounting bracket may be obstructed by the GFCI Cover. Remove the GFCI cover to provide access to these holes.

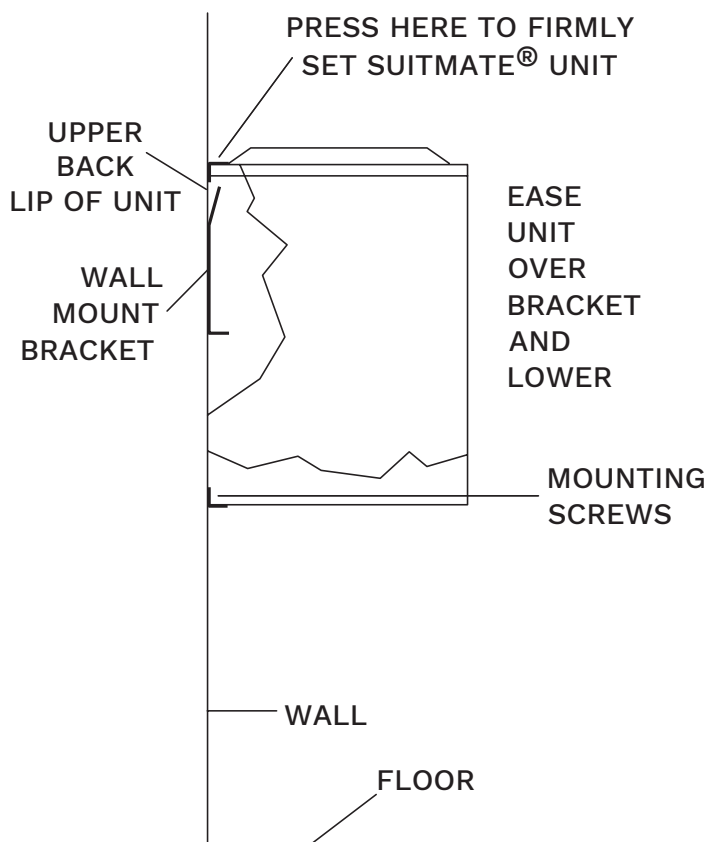

CUTAWAY VIEW OF SUITMATE® UNIT

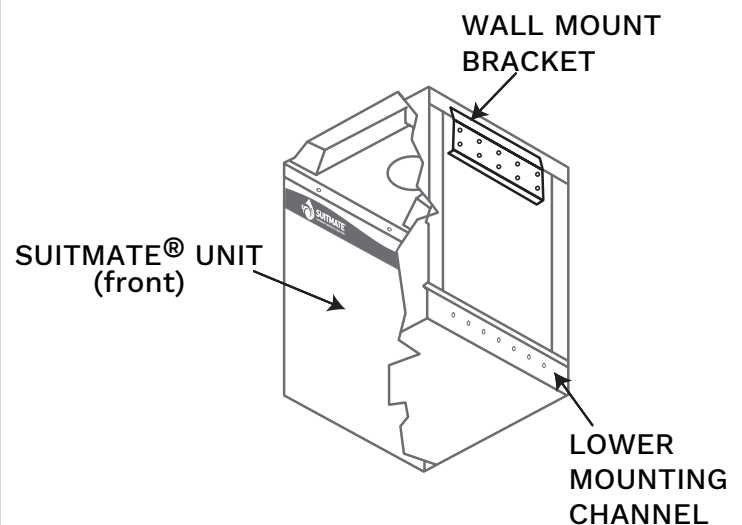

USE APPROPRIATE ANCHORS AND FASTENERS TO MOUNT THE UNIT FOR YOUR SPECIFIC INSTALLATION

PROPER DRAINAGE FOR THE SUITMATE® UNIT

Note: *Strictly follow all applicable local plumbing codes and regulations.*

TO A FLOOR DRAIN

Drainage of the wastewater to a floor drain should be done ONLY in an area where the floor is normally wet. DO NOT drain water across a floor where people do not expect to encounter a wet and slippery condition. The SUITMATE® unit comes with a short drain hose and a stainless steel hose clamp that can be used to attach it to the unit's drain tailpiece.

WARNING!

The factory supplied drain hose or applicable equivalent MUST be installed on the unit unless the unit is connected to an approved wastewater outlet.

Replacing the Factory Drain Hose with a Longer Drain Hose

Use a 3.5 cm (1³/₈ in) I.D. drain hose with a smooth interior that will not crimp or collapse. Use the stainless steel hose clamp that is provided with the factory supplied drain hose to secure the replacement hose to the unit's drain tailpiece. Ensure the replacement drain hose always slopes down, and secure it to the wall or floor with properly sized "U" clamps so it cannot be maneuvered to trap wastewater. Cut off the end of the drain hose on an angle to help prevent it from being blocked by the floor, wall, or some other object. Upon completion of the installation, check to make certain that there is a free flow of water from the drain hose.

TO AN APPROVED SANITARY WASTE LINE

This installation should only be done in accordance with all applicable local plumbing codes and regulations. The unit's 3 cm (1³/₁₆ in) O.D. drain tailpiece is designed for connection with standard compression type plumbing fittings. There is room inside of the stainless steel housing for the use of a standard "P" type plumbing connection. The waste outlet should be located in the wall behind the unit. The UTILITIES LOCATION DIAGRAM (available at www.suitmate.com under RESOURCES) shows the appropriate location for the waste duct.

PROPER ELECTRICAL CONNECTIONS FOR THE SUITMATE® UNIT

Note: *Strictly follow all applicable local electrical codes and regulations.*

The SUITMATE® unit is equipped with a ground fault circuit interrupter (GFCI), that is designed to be connected to a 115 V, 60 Hz, 20 A dedicated circuit that is protected by a fuse or circuit breaker of the correct (20 A Maximum) size. A PLUG-IN INSTALLATION IS NOT ACCEPTABLE! The utilized circuit must be run to the SUITMATE® unit's weatherproof Junction Box that contains the GFCI. A liquid tight flexible conduit should be used from the circuit connection to the GFCI Junction Box. The UTILITIES LOCATION DIAGRAM (available at www.suitmate.com under RESOURCES) shows the location of the suggested area behind the unit for the entrance of the flexible conduit that does not interfere with the drainage connection.

WARNING!

Do not route the conduit where wastewater can flow or drip on it.

Remove the cover of the weatherproof Junction Box, which contains the GFCI, and remove the GFCI mounting screws. The circuit ground conductor must be connected to the Green Ground Screw located on the GFCI. If no ground is available on the circuit utilized, you must provide a proper ground for the SUITMATE® unit. The hot and neutral leads of the power circuit should be connected to the GFCI screw terminals marked "LINE". Connect the hot lead to the terminal marked "HOT WIRE" and the neutral lead to the terminal marked "WHITE WIRE". After the correct electrical connections have been properly made, remount the GFCI using the screws previously removed. Reinstall the weatherproof Junction Box cover previously removed. This cover provides access to the GFCI "TEST" and "RESET" buttons.

SUITMATE® WIRING DIAGRAM

115 V, 60 Hz, 8.6 A SUITMATE® Unit

CUSTOMER'S ELECTRICAL SERVICE

115 V, 60 Hz, 20 A Dedicated Circuit

SUITMATE® UNIT

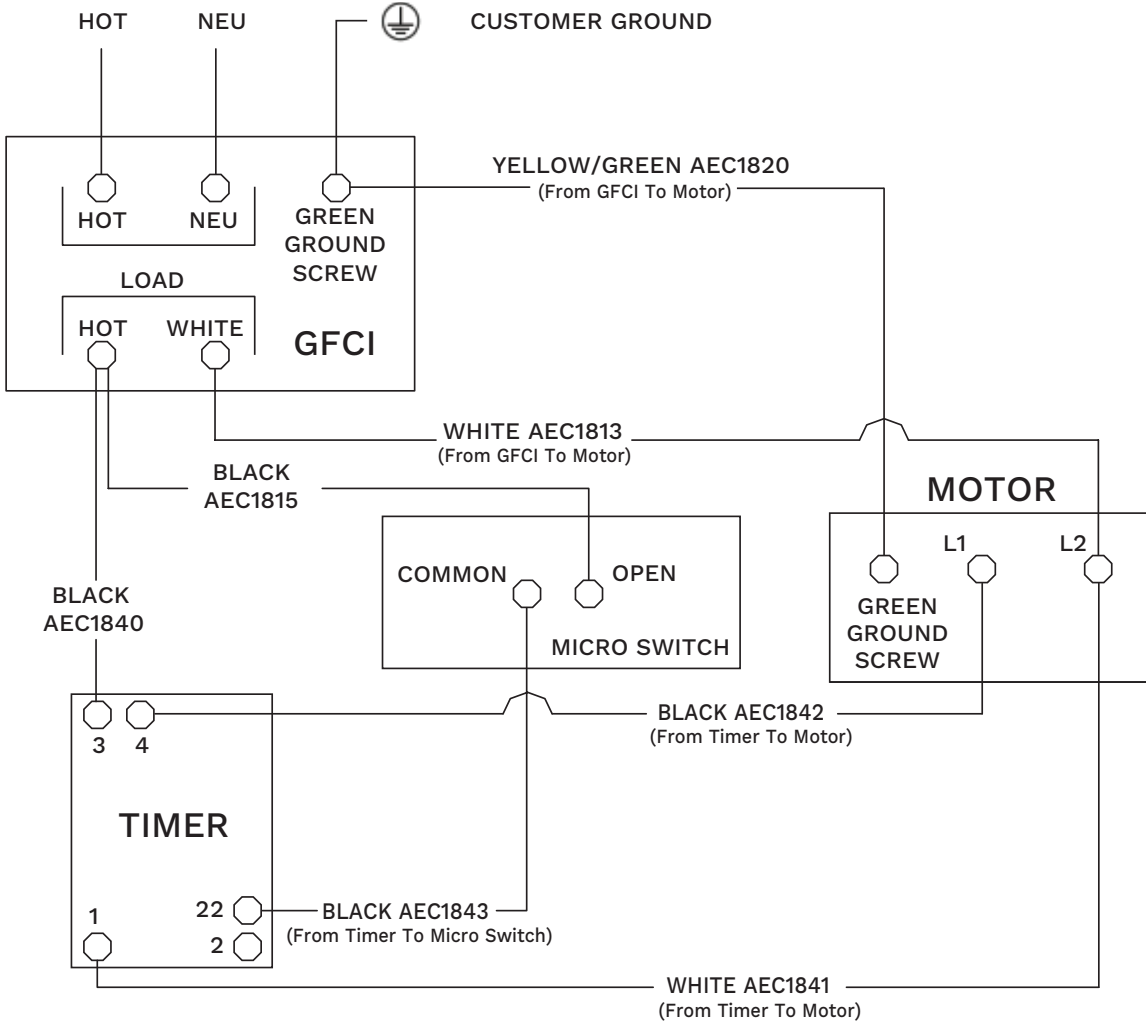

POSTING THE WALL SIGN

Locate the top edge of the sign 152.4 cm +/- 1.6 mm (60+/- 1/16 in) above the floor centered over the SUITMATE® unit. At this height the sign will not be blocked when the Lid is raised.

The sign has an adhesive foam backing. Be certain the surface that the sign is to be mounted to is clean and dry. Without touching the sign to the wall, align the top of the sign 152.4 cm +/- 1.6 mm (60+/- 1/16 in) above the floor and at the center of the unit. Press the sign to the wall and rub firmly over the adhesive portion of the sign.

TESTING AND OPERATION

After the mounting and all connections are complete, test the SUITMATE® unit as follows:

1. Check to see that the Basket is empty and that the Lid moves freely.
2. To start unit, close and hold Lid down firmly for 8 seconds.
3. Releasing the Lid causes the Basket to stop within one (1) second.
4. Test the SUITMATE® unit by putting a wet swimsuit in the unit according to the instructions on the underside of the Lid. If there is excessive vibration or noise it is usually caused by the improper loading of the swimsuit. Be certain that the swimsuit is pushed to the bottom of the Basket and that all material is at least 5 cm (2 in) below the top of the Basket.

INSTALLATION TROUBLESHOOTING

If the SUITMATE® unit does not operate, check the following:

1. Check to see if there is power going to and from the unit.
 - Check the circuit using an A.C. voltmeter set to measure across the “LINE” side of the GFCI.
 - Check the unit using an A.C. voltmeter to measure across the “LOAD” side of the GFCI.
2. Ensure that the GFCI switch is in the “ON” position. The “RESET” button should be depressed and a small green light should be illuminated.
3. Check the TROUBLESHOOTING GUIDE (page 12) in this manual for additional troubleshooting assistance.

FINISHING THE INSTALLATION

Be certain to save this SUITMATE® UNIT MANUAL for future reference. If you have any concerns about the correct installation of the SUITMATE® unit, please contact Extractor Corporation at: (Toll Free) 800-553-3353, (Telephone) 847-742-3532, or (E-Mail) info@suitmate.com.